



2023 Disc Wheel Hub Redesign

We would like to advise you of several design changes to the popular N-spindle disc wheel hub, the Webb 2023.

This update includes a variety of features that will improve the hub's serviceability while maintaining its functionality and 12,500 lb. dynamic hub rating (25,000 lb. GAWR Rating). Among these changes include a volume increase in lubrication cavity, change in 3/4" BSN studs, and visual appearance.

These aspects are outlined below.

Change in Lubrication Cavity Volume

The volume of oil or grease required for the newly revised 2023 varies from previous revisions. These changes are outlined in Webb's TSB 14-001 "Trailer Hub Lubrication Volume".

Change in Ball-Seat (Stud-Piloted) Studs

The redesigned 2023 casting revision K requires different 3/4" BSN studs for appropriate stud stand-out due to flange thickness reduction. Please reference the chart below for proper 3/4" stud part numbers.

3/4" Stud Part Number for BSN Mounting Systems		
Thread Orientation	2023 Hub Casting (Rev's A through J)	2023 Hub Casting (Rev's K and Beyond)
Right Hand	101172	101170
Left Hand	101173	101171

*Please note that this change does not affect M22 studs for FN, Hub-Piloted systems.

Visual Difference

2023 Hub Casting Rev's A Through J

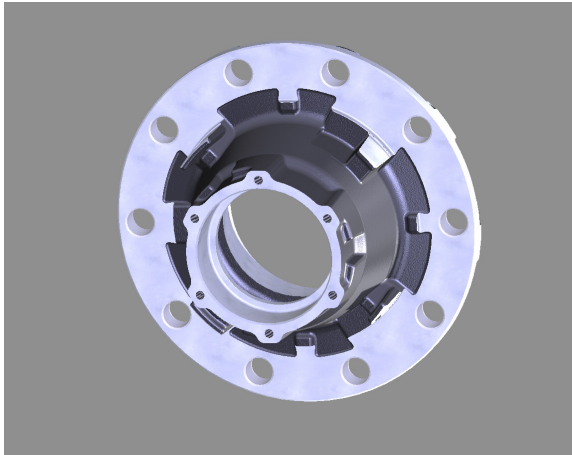

2023 Hub Casting Rev's K and Beyond

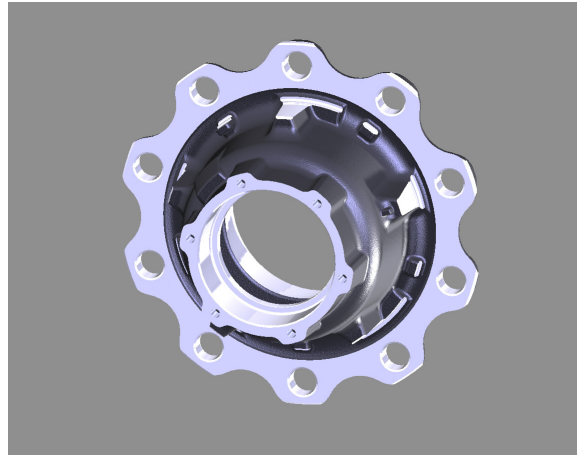

The hub's casting revision level is identified by raised lettering located on the inboard side of the hub.

If you have any questions, please contact the Webb Engineering department via email to engineering@webbwheel.com or call 256-739-6660.